

NOZ₂

Technical Details



Biddle



NOZ₂

The NOZ₂ range is specifically designed for large buildings with high ceilings such as factories, retail outlets, sports centres and exhibition halls. Their innovative multi-directional design induces movement in the air around the unit ensuring warm or cool air is distributed evenly throughout the room. As a result, they are not only more effective than conventional products they are also more efficient, delivering energy savings of up to 15% compared to traditional products.

NOZ₂ WATER HEATED & AMBIENT

PAGE 5

Warm air naturally rises, NOZ₂ heaters capture it at ceiling height and optimise its distribution at floor level using the inductive effect. When used with Biddle's intelligent automatic controls, the fan speed and heat output are automatically adjusted to ensure a consistent, comfortable climate is maintained at floor level without any user intervention.

NOZ₂ GAS

PAGE 21

NOZ₂ Gas heaters circulate warm air in the same way as NOZ₂ water heated and ambient units, using the induction effect to optimise distribution throughout the room. Gas air heater units have an integrated closed system gas burner. This gas burner draws in air from outside and exhausts combustion gases externally. Heat output is automatically regulated by an intelligent MultiTherm C Thermostat.

NOZ₂ COOLING

PAGE 29

The latest addition to the NOZ₂ range, NOZ₂ Cooling provides both heating and cooling from a single unit. NOZ₂ Cooling works in combination with a cold and warm water source. Warm air is drawn into the NOZ₂, cooled, then released and distributed evenly throughout the room using the induction effect. Condensation from the cooling process is collected by a built-in demister, and can be drained away using a gravity drain or a mechanical pump, therefore there is no restriction on where the cooling unit can be sited.

NOZ₂ WATER HEATED & AMBIENT

Technical Details



Biddle

FOR THE RIGHT NOZ₂

There are two models available in the NOZ₂ water heated & ambient range. The models are designed to be mounted at different heights as shown in the table below.

	Mounting height ¹	Influence area
NOZ ₂ 25	2.8 – 8.5m	100 – 400m ²
NOZ ₂ 50	3.5 – 14.0m	200 – 800m ²

¹ The mounting height is measured from the bottom of the unit to the floor.

IDEAL DISCHARGE DIRECTION

To optimise the distribution of the discharged air, the nozzles can be adjusted. The ideal discharge direction depends on the influence area and the mounting height. These two factors have a significant influence on the selection of the NOZ₂.

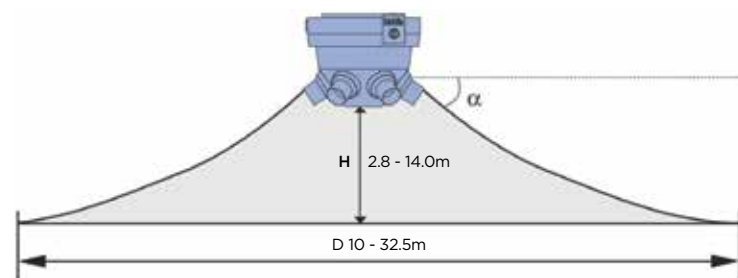

Representation of the mounting height (H) and the diameter of the heated floor area (D).

The completion of the below steps will lead to the ideal discharge direction and the correct selection of the NOZ₂.

1. INFLUENCE AREA (HEATED FLOOR AREA)

Based on the dimensions of the room, the diameter (D) of the heated floor area will be determined. Due to the inducing effect of the NOZ₂ a larger area will be heated than the diameter of the targeted area.

2. MOUNTING HEIGHT

The mounting height (H) is the distance between the floor and the bottom of the unit.

3. IDEAL DISCHARGE DIRECTION

By means of the table on the next page the correct nozzle angle (α) can be selected.

4. MODEL AND NUMBER OF NOZ₂ AIR HEATERS

By means of the table on the next page the NOZ₂ model and the number of devices can be selected.

5. SELECTION NOZ₂

The selection depends on the applied heat source (water, ambient or gas), the desired room temperature and the power consumption (kW). The final selection of the NOZ₂ is based on the technical data.

DISCHARGE DIRECTION AND SELECTION

Due to the strong inductive effect, the induction flow rate is 10 times the primary air displacement and the temperature gradient is only 0.25°C per metre contrary to conventional air heaters. By applying a NOZ₂ on average 15% will be saved on the power consumption (kW) (based on ISSO 57 heat loss calculation - The Netherlands).

NOZZLE ANGLE BASED ON MOUNTING HEIGHT AND DIAMETER OF THE HEATED FLOOR AREA

D [m]	10	12.5	15	17.5	20	22.5	25	27.5	30	32.5
H [m]										
3	42	36	31	27	24	22	-	-	-	-
4	50	44	39	34	31	28	26	24	22	20
5	-	50	45	41	37	34	31	29	27	25
6	-	-	50	46	42	39	36	33	31	29
7	-	-	-	50	46	43	40	37	35	33
8	-	-	-	-	50	47	44	41	39	36
9	-	-	-	-	53	50	47	44	42	40
10	-	-	-	-	-	53	50	47	45	43
11	-	-	-	-	-	-	53	50	48	45
12	-	-	-	-	-	-	-	53	50	48
13	-	-	-	-	-	-	-	-	52	50
14	-	-	-	-	-	-	-	-	-	52

NOZ₂ 25 NOZ₂ 50

EXAMPLE NOZ₂ SELECTION

ROOM DATA:

Dimensions: 30 x 15m, height: 6m
 Room temperature: 15°C
 Water range: 80/60°C
 Heat loss (conventional): 54kW

STEPS:

1. D = 15 or 30 (depending on NOZ₂ model)
2. H = 5m
3. α = 45 or 27 (depending on NOZ₂ model)
4. 2 x NOZ₂ 25 or 1 x NOZ₂ 50
5. kW = 46 (-15% compared to conventional air heaters)

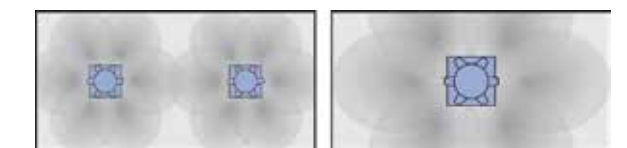
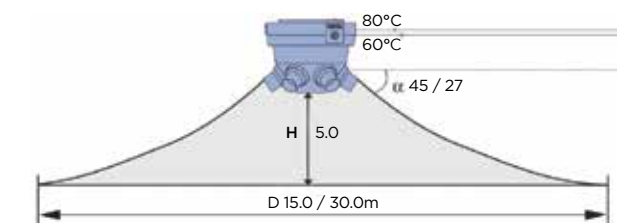

2 x NOZ₂ 25 or 1 x NOZ₂ 50

Based on the NOZ₂ technical data (with an air inlet temperature of 15°C) the below maximal heating capacities apply for each model. Because the NOZ₂ 25 with the H2 heating coil just does not meet the required power of 46 kW, the maximal heating capacity is also calculated for the H3 heating coil. To convert the H3 coil to 80/60°C the correction factor is 1,71.

- 2 x NOZ₂ 25: H2 = 42.2 kW, H3 = 72.6 kW and 1 x NOZ₂ 50: H2 = 46.7 kW

The final choice depends on more factors like the layout and function of the room and the required sound level. Based on the total overview the choice will be made between 2 x NOZ₂ 25-H3 or 1 x NOZ₂ 50-H2.

WATER HEATED & AMBIENT VERSIONS

With regard to control and mounting of the NO₂ air heater various accessories are available.

STANDARD DELIVERY

- Energy efficient EC fans (stepless control)
- Integrated isolation switch

CONTROL / OPERATION

- Automatic control incl. CHIPS technology or Basic control

CONTROL ACCESSORIES AUTOMATIC CONTROL

- b-touch control panel
- Room temperature sensor
- Water-side control: valve and actuator (not in ambient version)
- Biddle low-voltage cable (35m)

BASIC CONTROL

- b-control: potentiometer (0-10 Volt)
- Optional: room thermostat

INSTALLATION

There are two options for the installation of the NO₂:

- Optional: suspension frame for quick and easy installation
- Via M8 threaded rods

OPTIONAL

- Combination of recirculation with ventilation (see ventilation information sheet)
- Plastic caps to cover maximum 2 nozzles
- Separate flange set for hot water connection



Suspension Frame



b-touch Control Panel

TYPES OF WATER COILS

STANDARD: H2 (2-row), H3 (3-row) and H6 (6-row)

The NO₂ with automatic control can be provided for many water ranges (maximum water temperature 120°C). The discharge temperature is limited by the control to 50°C. In the case of an uncontrolled basic model, consideration should be given to the maximum temperatures of 90/70°C for the H2, 80/60°C for the H3 and 60/40 °C for the H6.

ON REQUEST: H1p (1-row)

Suitable for high water temperatures (130/110°C, 150/130°C and 175/155°C) and for high pressure (maximum 23.8 bar). Delivered with welded flanges.

VENTILATION VERSION

NO₂ is available in a ventilation model in order to supply a room with fresh outside air.

STANDARD DELIVERY

- Frost-protection thermostat:
 - automatic control: installed and wired
 - basic control: installed, but not wired

VENTILATION ACCESSORIES

- Roof cap
- Duct sections: length 0.5 - 1 and 1.5m
- Filter module: filter class G2

AUTOMATIC CONTROL

- Damper section incl. installed and wired servomotor is necessary

BASIC CONTROL

- Damper section:
 - excl. servomotor
 - incl. servomotor with pull-back spring (not wired)
 - incl. servomotor without pull-back-spring return (not wired)

TYPES OF DAMPER SECTIONS

3-way: this is used in a combination of ventilation (supply of outside air) and recirculation (intake of inside air). The proportion of these two air flows can, if required, be controlled. Even in times of frost danger, the recirculation function may be used to heat the room.

1-way: this is used in assemblies involving 100% ventilation, so that no moisture loss or heat loss occurs when the air heater is not operating.



Roof Cap



3-way Damper Section



1-way Damper Section



Filter Module

ELECTRICAL CONNECTIONS

The NOZ₂ is delivered as standard with a built in isolation switch, to which the 230V or 400V supply cable can be connected.

AUTOMATIC CONTROL



BASIC CONTROL



SPECIFICATIONS

CASING

The casing of the air heater is made of zinc plated sheet steel and has an inspection panel at the side. The cone, nozzles and the ring are made of plastic. The unit is delivered as standard in two colours: in RAL 5011/RAL9006 (steel blue/aluminium) or in RAL 9006 (aluminium). Other RAL colours are available at an extra charge.

HEATING COIL

The high efficient heating coils are made up of 3/8" copper pipes and aluminium fins. The water connections for the NOZ₂ 25 are G 3/4" and for the NOZ₂ 50 G1". These connections are located on the side of the unit.

MOTOR / FAN ASSEMBLY

The fan is made up of a plastic (NOZ₂ 25) or an aluminium (NOZ₂ 50) impeller and an external rotor motor with EC technology. If overheated, the motor is protected by thermal contacts, which will break the electrical circuit.



NOZ₂ 25-H2

Mounting height	m	2.8 - 8.5				
Influence area	m ²	100 - 400				
Electrical supply	V/ph/Hz	230/1+N/50				
Max. input current	A	1.8				
Max. input power	kW	0.41				
Max. specific fan power	W/l/s	0.39				
Weight	kg	37.0				
Water range	°C	80/60				
Speed		2V	4V	6V	8V	10V
Air volume	m ³ /h	524.0	1365.0	2133.0	2926.0	3759.0
Power consumption	kW	0.1	0.1	0.1	0.3	0.5
Sound pressure level at 5m	dB(A)	17.0	31.0	44.0	53.0	60.0
Air inlet temperature	°C	-10				
Heating capacity	kW	9.8	18.5	24.1	28.8	32.8
Discharge air temperature	°C	40.1	26.2	20.2	16.2	13.3
Water flow rate	l/h	431.0	811.0	1056.0	1260.0	1439.0
Water pressure drop	kPa	0.7	2.4	3.8	5.3	6.7
Air inlet temperature	°C	0				
Heating capacity	kW	8.4	15.8	20.6	24.6	28.1
Discharge air temperature	°C	44.3	32.0	26.7	23.3	20.7
Water flow rate	l/h	367.0	692.0	902.0	1077.0	1231.0
Water pressure drop	kPa	0.6	1.8	2.9	4.0	5.1
Air inlet temperature	°C	10				
Heating capacity	kW	7.0	13.2	17.2	20.5	23.4
Discharge air temperature	°C	48.2	37.7	33.1	30.1	27.9
Water flow rate	l/h	306.0	577.0	753.0	899.0	1028.0
Water pressure drop	kPa	0.4	1.3	2.1	2.8	3.6
Air inlet temperature	°C	15				
Heating capacity	kW	6.4	11.9	15.5	18.5	21.2
Discharge air temperature	°C	50.6	40.4	36.2	33.5	31.4
Water flow rate	l/h	280.0	521.0	679.0	811.0	928.0
Water pressure drop	kPa	0.3	1.0	1.7	2.4	3.0
Air inlet temperature	°C	18				
Heating capacity	kW	6.0	11.1	14.5	18.5	19.8
Discharge air temperature	°C	51.7	42.0	38.1	35.5	33.5
Water flow rate	l/h	262.0	488.0	636.0	759.0	868.0
Water pressure drop	kPa	0.3	0.9	1.5	2.1	2.7
Air inlet temperature	°C	20				
Heating capacity	kW	5.7	10.6	13.9	16.5	18.9
Discharge air temperature	°C	52.4	43.1	39.3	36.8	34.9
Water flow rate	l/h	250.0	466.0	607.0	725.0	829.0
Water pressure drop	kPa	0.3	0.9	1.4	1.9	2.5

NOZ₂ 25-H3

Mounting height	m	2.8 - 8.5				
Influence area	m ²	100 - 400				
Electrical supply	V/ph/Hz	230/1+N/50				
Max. input current	A	1.8				
Max. input power	kW	0.39				
Max. specific fan power	W/l/s	0.38				
Weight	kg	39.0				
Water range	°C	60/40				
Speed		2V	4V	6V	8V	10V
Air volume	m ³ /h	511.0	1322.0	2078.0	2859.0	3674.0
Power consumption	kW	0.1	0.1	0.1	0.3	0.4
Sound pressure level at 5m	dB(A)	17.0	31.0	43.0	53.0	60.0
Air inlet temperature	°C	-10				
Heating capacity	kW	9.0	17.9	23.9	28.9	33.4
Discharge air temperature	°C	37.3	26.1	20.7	17.0	14.2
Water flow rate	l/h	393.0	775.0	1036.0	1256.0	1449.0
Water pressure drop	kPa	0.7	2.4	4.1	5.8	7.6
Air inlet temperature	°C	0				
Heating capacity	kW	7.4	14.4	19.3	23.4	27.0
Discharge air temperature	°C	40.1	30.2	25.7	22.6	20.3
Water flow rate	l/h	321.0	626.0	837.0	1013.0	1169.0
Water pressure drop	kPa	0.5	1.6	2.8	3.9	5.1
Air inlet temperature	°C	10				
Heating capacity	kW	5.7	11.1	14.8	17.9	20.7
Discharge air temperature	°C	42.2	34.1	30.5	28.0	26.1
Water flow rate	l/h	248.0	482.0	643.0	778.0	897.0
Water pressure drop	kPa	0.3	1.0	1.7	2.4	3.1
Air inlet temperature	°C	15				
Heating capacity	kW	4.9	9.5	12.6	15.3	17.6
Discharge air temperature	°C	43.1	35.9	32.7	30.6	29.0
Water flow rate	l/h	213.0	412.0	548.0	662.0	763.0
Water pressure drop	kPa	0.2	0.8	1.3	1.8	2.3
Air inlet temperature	°C	18				
Heating capacity	kW	4.4	8.5	11.3	15.3	15.7
Discharge air temperature	°C	43.6	37.0	34.1	32.1	30.6
Water flow rate	l/h	192.0	370.0	491.0	593.0	683.0
Water pressure drop	kPa	0.2	0.6	1.0	1.5	1.9
Air inlet temperature	°C	20				
Heating capacity	kW	4.1	7.9	10.5	12.6	14.5
Discharge air temperature	°C	43.9	37.7	34.9	33.1	31.7
Water flow rate	l/h	179.0	342.0	454.0	548.0	630.0
Water pressure drop	kPa	0.2	0.5	0.9	1.3	1.7

NOZ₂ 25-H6

Mounting height	m	2.8 - 8.5				
Influence area	m ²	100 - 400				
Electrical supply	V/ph/Hz	230/1+N/50				
Max. input current	A	1.3				
Max. input power	kW	0.290				
Max. specific fan power	W/l/s	0.32				
Weight	kg	47.0				
Water range (heating)	°C	50/30				
Inlet air relative humidity	%	50				
Speed		2V	4V	6V	8V	10V
Air volume	m ³ /h	443.0	1088.0	1785.0	2494.0	3215.0
Power consumption	kW	0.100	0.100	0.100	0.200	0.300
Sound pressure level at 5m	dB(A)	16.0	31.0	43.0	52.0	59.0
Air inlet temperature	°C	-10				
Heating capacity	kW	8.8	18.9	27.7	35.4	42.2
Discharge air temperature	°C	43.3	36.3	31.5	27.9	25.0
Water flow rate	l/h	382.0	816.0	1199.0	1529.0	1822.0
Water pressure drop	kPa	0.6	2.4	4.9	7.7	10.6
Air inlet temperature	°C	0				
Heating capacity	kW	6.9	14.7	21.5	27.4	32.6
Discharge air temperature	°C	43.5	37.5	33.4	30.4	28.1
Water flow rate	l/h	300.0	636.0	931.0	1185.0	1411.0
Water pressure drop	kPa	0.4	1.5	3.1	4.8	6.6
Air inlet temperature	°C	10				
Heating capacity	kW	5.1	10.7	15.5	19.7	23.4
Discharge air temperature	°C	43.3	38.2	35	32.7	30.9
Water flow rate	l/h	222.0	463.0	672.0	852.0	1011.0
Water pressure drop	kPa	0.2	0.9	1.7	2.6	3.6
Air inlet temperature	°C	15				
Heating capacity	kW	4.2	8.7	12.6	15.9	18.8
Discharge air temperature	°C	43.0	38.4	35.6	33.6	32.1
Water flow rate	l/h	183.0	377.0	544.0	687.0	813.0
Water pressure drop	kPa	0.2	0.6	1.2	1.8	2.4
Air inlet temperature	°C	18				
Heating capacity	kW	3.7	7.5	10.8	15.9	16.0
Discharge air temperature	°C	42.6	38.4	35.8	34.1	32.7
Water flow rate	l/h	160.0	325.0	466.0	587.0	693.0
Water pressure drop	kPa	0.1	0.5	0.9	1.3	1.8
Air inlet temperature	°C	20				
Heating capacity	kW	3.3	6.7	9.6	12.0	14.2
Discharge air temperature	°C	42.3	38.3	35.9	34.3	33.1
Water flow rate	l/h	144.0	290.0	414.0	519.0	611.0
Water pressure drop	kPa	0.1	0.4	0.7	1.1	1.4

NOZ₂ 50-H2

Mounting height	m	3.5 - 14.0				
Influence area	m ²	200 - 800				
Electrical supply	V/ph/Hz	400/3+N/50				
Max. input current	A	3.1				
Max. input power	kW	1.94				
Max. specific fan power	W/l/s	0.76				
Weight	kg	64.0				
Water range (heating)	°C	80/60				
Inlet air relative humidity	%	50				
Speed		2V	4V	6V	8V	10V
Air volume	m ³ /h	1523.0	3534.0	5611.0	7346.0	9236.0
Power consumption	kW	0.100	0.200	0.500	1.100	2.000
Sound pressure level at 5m	dB(A)	28.0	42.0	54.0	62.0	69.0
Air inlet temperature	°C	-10				
Heating capacity	kW	25.3	43.0	56.0	64.6	72.6
Discharge air temperature	°C	34.3	22.5	16.6	13.5	11.0
Water flow rate	l/h	1110.0	1886.0	2453.0	2832.0	3181.0
Water pressure drop	kPa	1.1	3.1	5.0	6.5	8.0
Air inlet temperature	°C	0				
Heating capacity	kW	21.6	36.7	47.8	55.2	62.1
Discharge air temperature	°C	39.2	28.8	23.6	20.8	18.6
Water flow rate	l/h	945.0	1609.0	2095.0	2421.0	2721.0
Water pressure drop	kPa	0.9	2.3	3.7	4.8	6.0
Air inlet temperature	°C	10				
Heating capacity	kW	18.0	30.6	39.9	46.1	51.8
Discharge air temperature	°C	43.8	34.8	30.4	28.0	26.1
Water flow rate	l/h	788.0	1341.0	1747.0	2019.0	2270.0
Water pressure drop	kPa	0.6	1.6	2.7	3.5	4.3
Air inlet temperature	°C	15				
Heating capacity	kW	16.2	27.6	36.0	41.6	46.7
Discharge air temperature	°C	46.1	37.8	33.7	31.5	29.8
Water flow rate	l/h	711.0	1210.0	1576.0	1822.0	2048.0
Water pressure drop	kPa	0.5	1.3	2.2	2.9	3.6
Air inlet temperature	°C	18				
Heating capacity	kW	15.2	25.8	33.6	41.6	43.7
Discharge air temperature	°C	47.4	39.6	35.7	33.6	32.0
Water flow rate	l/h	665.0	1132.0	1475.0	1704.0	1916.0
Water pressure drop	kPa	0.4	1.2	1.9	2.5	3.1
Air inlet temperature	°C	20				
Heating capacity	kW	14.5	24.7	32.1	37.1	41.7
Discharge air temperature	°C	48.2	40.7	37.0	35.0	33.4
Water flow rate	l/h	635.0	1081.0	1407.0	1626.0	1829.0
Water pressure drop	kPa	0.4	1.1	1.8	2.3	2.9

NOZ₂ 50-H3

Mounting height	m	3.5 - 14.0				
Influence area	m ²	200 - 800				
Electrical supply	V/ph/Hz	400/3+N/50				
Max. input current	A	3				
Max. input power	kW	1.85				
Max. specific fan power	W/l/s	0.74				
Weight	kg	67.0				
Water range (heating)	°C	60/40				
Inlet air relative humidity	%	50				
Speed		2V	4V	6V	8V	10V
Air volume	m ³ /h	1466.0	3457.0	5502.0	7207.0	9046.0
Power consumption	kW	0.100	0.200	0.400	1.000	1.900
Sound pressure level at 5m	dB(A)	28.0	42.0	54.0	62.0	69.0
Air inlet temperature	°C	-10				
Heating capacity	kW	23.7	42.6	56.7	66.2	74.9
Discharge air temperature	°C	33.2	22.9	17.5	14.5	12.1
Water flow rate	l/h	1029.0	1850.0	2459.0	2870.0	3249.0
Water pressure drop	kPa	1.4	4.1	6.9	9.2	11.5
Air inlet temperature	°C	0				
Heating capacity	kW	19.2	34.4	45.8	53.4	60.5
Discharge air temperature	°C	36.2	27.6	23.0	20.5	18.5
Water flow rate	l/h	833.0	1494.0	1986.0	2319.0	2625.0
Water pressure drop	kPa	1.0	2.8	4.7	6.2	7.8
Air inlet temperature	°C	10				
Heating capacity	kW	14.8	26.5	35.2	41.1	46.4
Discharge air temperature	°C	39.0	32.0	28.3	26.3	24.7
Water flow rate	l/h	644.0	1150.0	1527.0	1781.0	2015.0
Water pressure drop	kPa	0.6	1.7	2.9	3.8	4.8
Air inlet temperature	°C	15				
Heating capacity	kW	12.7	22.6	30.0	35.0	39.5
Discharge air temperature	°C	40.3	34.1	30.9	29.2	27.8
Water flow rate	l/h	552.0	982.0	1301.0	1517.0	1715.0
Water pressure drop	kPa	0.4	1.3	2.2	2.8	3.6
Air inlet temperature	°C	18				
Heating capacity	kW	11.5	20.3	26.9	35.0	35.4
Discharge air temperature	°C	41.0	35.3	32.4	30.8	29.5
Water flow rate	l/h	497.0	882.0	1167.0	1359.0	1536.0
Water pressure drop	kPa	0.4	1.1	1.8	2.3	2.9
Air inlet temperature	°C	20				
Heating capacity	kW	10.6	18.8	24.8	28.9	32.7
Discharge air temperature	°C	41.5	36.1	33.4	31.9	30.7
Water flow rate	l/h	461.0	815.0	1077.0	1254.0	1417.0
Water pressure drop	kPa	0.3	0.9	1.5	2.0	2.5

NOZ₂ 50-H6

Mounting height	m	3.5 - 14.0				
Influence area	m ²	200 - 800				
Electrical supply	V/ph/Hz	400/3+N/50				
Max. input current	A	2.2				
Max. input power	kW	1.340				
Max. specific fan power	W/l/s	0.60				
Weight	kg	76.0				
Water range (heating)	°C	50/30				
Inlet air relative humidity	%	50				
Speed		2V	4V	6V	8V	10V
Air volume	m ³ /h	1157.0	3039.0	4908.0	6454.0	8023.0
Power consumption	kW	0.100	0.200	0.300	0.700	1.400
Sound pressure level at 5m	dB(A)	27.0	42.0	53.0	62.0	68.0
Air inlet temperature	°C	-10				
Heating capacity	kW	21.8	47.8	67.8	81.7	94.2
Discharge air temperature	°C	40.4	31.9	26.8	23.8	21.3
Water flow rate	l/h	944.0	2064.0	2982.0	3532.0	4070.0
Water pressure drop	kPa	0.8	3.2	6.1	8.7	11.2
Air inlet temperature	°C	0				
Heating capacity	kW	17.0	36.9	52.2	62.8	72.3
Discharge air temperature	°C	40.7	33.6	29.4	26.9	24.9
Water flow rate	l/h	736.0	1595.0	2254.0	2714.0	3124.0
Water pressure drop	kPa	0.5	2.0	3.8	5.3	6.9
Air inlet temperature	°C	10				
Heating capacity	kW	12.4	26.4	37.1	44.5	51.0
Discharge air temperature	°C	40.8	34.9	31.7	29.8	28.2
Water flow rate	l/h	536.0	1142.0	1602.0	1921.0	2205.0
Water pressure drop	kPa	0.3	1.1	2.0	2.8	3.6
Air inlet temperature	°C	15				
Heating capacity	kW	10.1	21.2	29.6	35.4	40.5
Discharge air temperature	°C	40.5	35.4	32.6	31.0	29.7
Water flow rate	l/h	437.0	918.0	1278.0	1528.0	1749.0
Water pressure drop	kPa	0.2	0.7	1.3	1.9	2.4
Air inlet temperature	°C	18				
Heating capacity	kW	8.7	18.1	25.1	35.4	34.1
Discharge air temperature	°C	40.2	35.5	33.0	31.6	30.5
Water flow rate	l/h	377.0	782	1083.0	1290.0	1473.0
Water pressure drop	kPa	0.1	0.5	1.0	1.4	1.7
Air inlet temperature	°C	20				
Heating capacity	kW	7.8	16.0	22.0	26.1	29.8
Discharge air temperature	°C	40.0	35.6	33.3	32	31.0
Water flow rate	l/h	336.0	689.0	950.0	1129.0	1287.0
Water pressure drop	kPa	0.1	0.4	0.8	1.1	1.4

NOZ₂ 25-A

Electrical supply	V/ph/Hz	230/1+N/50				
Max. input current	A	1.9				
Max. input power	kW	0.43				
Max. specific fan power	W/l/s	0.4				
Weight	kg	29.0				
Speed		2V	4V	6V	8V	10V
Air volume	m ³ /h	534.0	1400.0	2176.0	2980.0	3827.0
Power consumption	kW	0.1	0.1	0.2	0.3	0.5
Sound pressure level at 5m	dB(A)	17.0	32.0	44.0	53.0	60.0

NOZ₂ 50-A

Electrical supply	V/ph/Hz	400/3+N/50				
Max. input current	A	3.3				
Max. input power	kW	2.01				
Max. specific fan power	W/l/s	0.77				
Weight	kg	58.0				
Speed		2V	4V	6V	8V	10V
Air volume	m ³ /h	1569.0	3596.0	5699.0	7458.0	9387.0
Power consumption	kW	0.1	0.2	0.5	1.1	2.1
Sound pressure level at 5m	dB(A)	29.0	42.0	54.0	62.0	70.0

CORRECTION FACTORS HEATING CAPACITY

The heating capacities stated in the tables are based on the following water ranges:

- H2: 80/60°C
- H3: 60/40°C
- H6: 50/30°C

The air inlet temperature is 15°C. If water and air inlet temperatures differ, the maximal heating capacity is to be multiplied by the correction factors from the tables below.

These are based on the NOZ₂ 25, the data for the NOZ₂ 50 do not differ significantly.

LPHW H2	Air inlet temperature							
	-10 °C	-5 °C	0 °C	+5 °C	+10 °C	+15 °C	+18 °C	+20 °C
110/90 °C ¹	2.21	2.1	1.98	1.87	1.75	1.64	1.57	1.53
100/80 °C ¹	2.0	1.88	1.77	1.65	1.54	1.43	1.36	1.32
90/70 °C	1.78	1.66	1.55	1.44	1.32	1.22	1.15	1.11
82/71 °C	1.75	1.64	1.52	1.41	1.3	1.19	1.13	1.08
80/60 °C	1.55	1.44	1.33	1.22	1.11	1.0	0.94	0.89
70/50 °C	1.33	1.22	1.11	1.0	0.89	0.78	0.72	0.68
60/40 °C	1.1	0.99	0.89	0.78	0.67	0.57	0.51	0.47
LPHW H3								
90/70°C ¹	3.0	2.81	2.61	2.43	2.24	2.06	1.95	1.88
80/60 °C	2.63	2.44	2.25	2.07	1.89	1.71	1.6	1.53
70/50 °C	2.27	2.08	1.89	1.71	1.53	1.35	1.25	1.18
60/40 °C	1.9	1.71	1.53	1.35	1.18	1.0	0.9	0.83
LPHW H6								
70/50 °C ¹	3.15	2.89	2.64	2.39	2.15	1.91	1.77	1.68
60/40 °C	2.68	2.42	2.18	1.93	1.7	1.46	1.32	1.23
50/30 °C	2.2	1.96	1.71	1.47	1.24	1.0	0.86	0.76

¹Water range not suitable in case of an uncontrolled basic model.

Automatic control: the discharge temperature is limited on 50°C.

With the ventilation model, air volume decreases (due to modules and ductwork).

The following guideline may be used:

- 1 module = 15% less than the table values
- 2 modules and duct work = 20% less than the table values

A decrease in air volume also leads to a decrease in heating capacity.

Using the formula, you may calculate the new heating capacity.

- 1 module = $Q_{new} = 0.93 \times Q_{table}$ value
- 2 modules and duct work = $Q_{new} = 0.90 \times Q_{table}$ value

If circumstances differ from those described here, such as different water temperatures or more than one unit in a single room, please do not hesitate to ask for our advice.

NOZ₂ WATER HEATED & AMBIENT

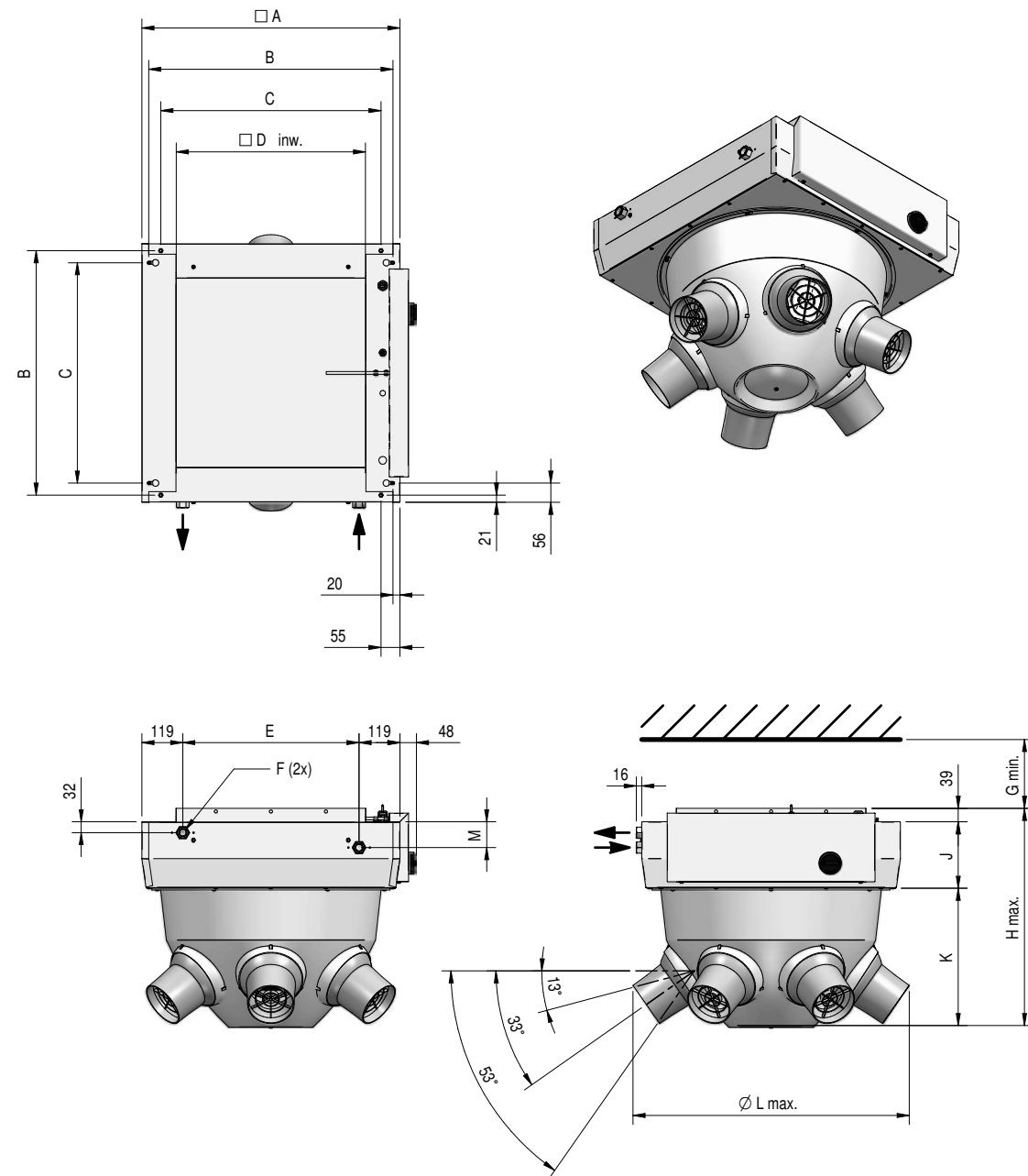

All measurements are in mm

	A	B	C	D	E	F	G	H	J	K	L	M
NOZ ₂ 25-A/H2/H3	750.0	710.0	640.0	550.0	512.0	G 3/4"	200.0	636.0	193.0	404.0	803.0	75.0
NOZ ₂ 25-H6/C6	750.0	710.0	640.0	550.0	512.0	G 3/4"	200.0	696.0	253.0	404.0	803.0	140.0
NOZ ₂ 50-A/H2/H3	975.0	935.0	865.0	775.0	737.0	G 1"	300.0	793.0	249.0	505.0	1016.0	75.0
NOZ ₂ 50-H6	975.0	935.0	865.0	775.0	737.0	G 1"	300.0	821.0	277.0	505.0	1016.0	140.0

NOZ₂ GAS

Technical Details



Biddle

A SUITABLE SOLUTION FOR EVERY SITUATION

POSSIBILITIES

- For mounting heights between 2.8 - 8.5m
- One model: NOZ₂ 25
- Gas heating: capacity 30kW
- Supply NOZ₂ 25: 230V

HEAT SOURCE

- Gas

GAS TYPES

- G20 / G25 - Natural gas
- G31 - Propane

IDEAL DISCHARGE DIRECTION

To optimise the distribution of the discharged air, the nozzles can be adjusted. The ideal discharge direction depends on the influence area and the mounting height. These two factors have a significant influence on the nozzle angle. For the correct setting of the nozzle angle see the general NOZ₂ brochure.



GAS VERSION

With regard to control and mounting of the NOZ₂ gas air heater various accessories are available.

STANDARD DELIVERY

- Energy efficient EC fans
- Integrated isolation switch

CONTROL / OPERATION

- MultiTherm C with integrated timer

CONTROL ACCESSORIES MULTITHERM C

- Control panel MultiTherm C with integrated timer
- External sensor for MultiTherm C

VARIOUS FLUE PIPE COMPONENTS ARE OPTIONAL

- Roof terminal: standard and long
- Wall terminal
- Weather slate: for angled or flat roofs
- Flue pipe sections - straight: Ø80mm, lengths: 0.25 - 0.5 - 1.0 and 2.0m
- Flue pipe sections - elbow: Ø80mm, 90° and 45°
- Wall bracket: Ø80mm

The maximum equivalent length for flue gas discharge is 9m. For every 90° elbow deduct 2m and for every 45° elbow deduct 1m. The maximum dry length is 4m (straight).

	Roof terminal (mm)	
	Standard	Long
A	1280.0	289.0
B	500.0	242.0
C	Ø80.0	Ø80.0
D	Ø125.0	Ø125.0

INSTALLATION

There are two options for the installation of the NOZ₂:

- Optional: suspension frame for quick and easy installation
- Via M8 threaded rods

OPTIONAL

- Combination of recirculation with ventilation (see ventilation information sheet).



Suspension Frame

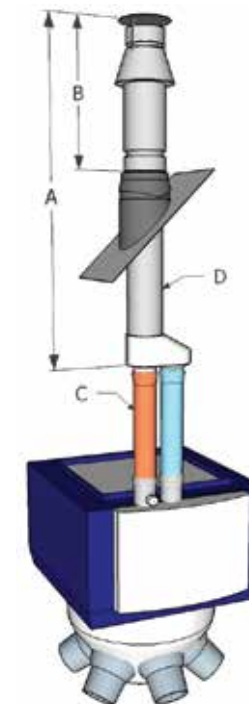

Roof Terminal

VENTILATION VERSION

NOZ₂ gas is available in a ventilation model in order to supply a room with fresh outside air.

ACCESSORIES VENTILATION

- Roof cap
- Duct sections: length 0.5 - 1 - 1.5m

3-WAY DAMPER SECTION:

- Damper section:
 - excl. servomotor
 - incl. servomotor with pull-back spring (not wired)
 - incl. servomotor without pull-back-spring return (not wired)

The 3-way damper section is used in a combination of ventilation (supply of outside air) and recirculation (intake of inside air). The proportion of these two air flows can, if required, be controlled. Even in times of frost danger, the recirculation function may be used to heat the room.



Roof Cap



3-way Damper Section

SPECIFICATIONS

CASING

The casing of the air heater is made of zinc plated sheet steel and has an inspection panel at the side. The cone, nozzles and the ring are made of plastic. The unit is delivered as standard in two colours: in RAL 5011/RAL9006 (steel blue/aluminium) or in RAL 9006 (aluminium). Other RAL colours are available at an extra charge.

MOTOR / FAN ASSEMBLY

The fan is made up of a plastic (NOZ₂ 25) and an external rotor motor with EC technology. If overheated, the motor is protected by thermal contacts, which will break the electrical circuit.

GAS CONNECTION

The gas connection for the NOZ₂ 25 is G 1/2". The connection is on top of the unit.



NOZ₂ 25-G20

Mounting height	m	2.8 - 8.5	
Electrical supply	V/ph/Hz	230/1+N/50	
Max. input current	A	2.35	
Max. fan power	kW	0.53	
Weight	kg	66.0	
Gas type		G20 (natural gas)	
Gas connection		G 1/2" (F)	
Nom. heat input	kW	20.5 - 32.0	
Nom. heat output	kW	19.1 - 29.2	
Max. gas consumption	m ³ /h	3.4	
Speed		Min.	Max.
Air volume	m ³ /h	1750.0	3170.0
Sound pressure level at 5m	dB(A)	42.0	58.0

NOZ₂ 25-G25

Mounting height	m	2.8 - 8.5	
Electrical supply	V/ph/Hz	230/1+N/50	
Max. input current	A	2.35	
Max. fan power	kW	0.53	
Weight	kg	66.0	
Gas type		G25 (natural gas)	
Gas connection		G 1/2" (F)	
Nom. heat input	kW	20.5 - 32.0	
Nom. heat output	kW	19.1 - 29.2	
Max. gas consumption	m ³ /h	3.8	
Speed		Min.	Max.
Air volume	m ³ /h	1750.0	3170.0
Sound pressure level at 5m	dB(A)	42.0	58.0

NOZ₂ 25-G31

Mounting height	m	2.8 - 8.5	
Electrical supply	V/ph/Hz	230/1+N/50	
Max. input current	A	2.35	
Max. fan power	kW	0.53	
Weight	kg	66.0	
Gas type		G31 (propane)	
Gas connection		G 1/2" (F)	
Nom. heat input	kW	20.5 - 32.0	
Nom. heat output	kW	19.1 - 29.2	
Max. gas consumption	m ³ /h	2.5	
Speed		Min.	Max.
Air volume	m ³ /h	1750.0	3170.0
Sound pressure level at 5m	dB(A)	42.0	58.0

NOZ₂ GAS

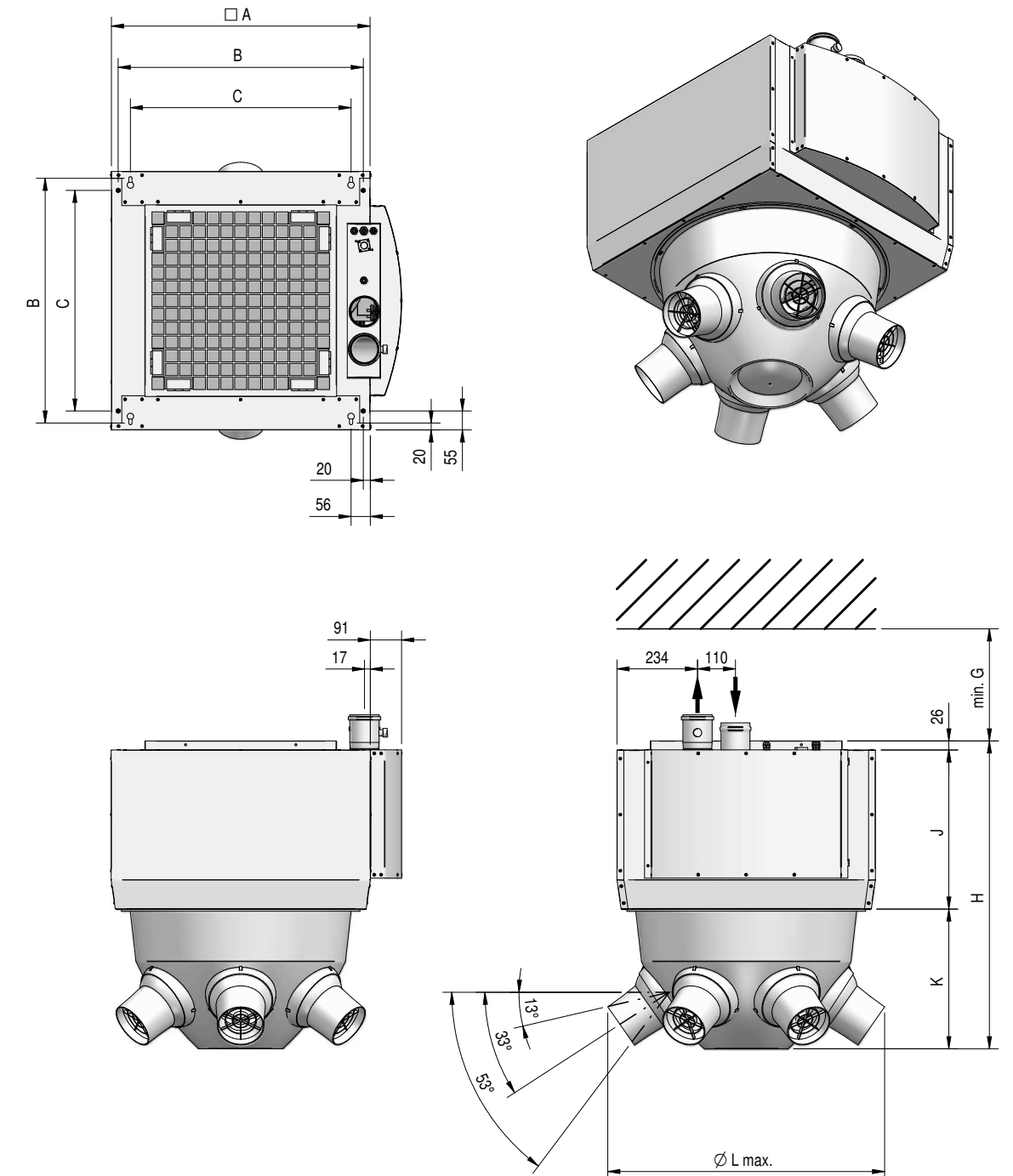

All measurements are in mm

	A	B	C	G	H	J	K	L
NOZ ₂ 25-GAS	750.0	710.0	640.0	700.0	893.0	461.0	404.0	803.0

NOZ₂ COOLING

Technical Details



Biddle

COOLING & CHANGE-OVER VERSIONS

With regard to control and mounting of the NO₂ cooling various accessories are available.

STANDARD DELIVERY

- Energy efficient EC fans (stepless control)
- Integrated isolation switch
- Integrated condensation droppatcher tray

CONTROL / OPERATION

- Automatic control incl. CHIPS technology or
- Basic control

CONTROL ACCESSORIES AUTOMATIC CONTROL

- b-touch control panel
- Room temperature sensor
- Water-side control: valve and actuator (not in ambient version)
- Biddle low-voltage cable (35m)

BASIC CONTROL

- b-control: potentiometer (0-10 Volt)
- Optional: room thermostat

INSTALLATION

- There are two options for the installation of the NO₂ cooling:
- Optional: suspension frame for quick and easy installation
 - Via M8 threaded rods

OPTIONAL

- Combination of recirculation with ventilation (see ventilation information sheet)
- Plastic caps to cover maximum 2 nozzles
- Separate flange set for hot water connection
- Condensate pump



Suspension Frame



b-touch Control Panel

VENTILATION VERSION

NO₂ cooling is available in a ventilation model in order to supply a room with fresh outside air.

STANDARD DELIVERY

- Frost-protection thermostat
 - automatic control: installed and wired
 - basic control: installed, but not wired

VENTILATION ACCESSORIES

- Roof cap
- Duct sections: length 0.5 - 1 and 1.5m
- Filter module: filter class G2

AUTOMATIC CONTROL

- Damper section incl. installed and wired servomotor is necessary

BASIC CONTROL

- Damper section:
 - excl. servomotor
 - incl. servomotor with pull-back spring (not wired)
 - incl. servomotor without pull-back-spring return (not wired)

TYPES OF DAMPER SECTIONS

3-way: this is used in a combination of ventilation (supply of outside air) and recirculation (intake of inside air). The proportion of these two air flows can, if required, be controlled. Even in times of frost danger, the recirculation function may be used to heat the room.

1-way: this is used in assemblies involving 100% ventilation, so that no moisture or heat loss occurs when the unit is not operating.



Roof Cap



3-way Damper Section



1-way Damper Section



Filter Module

NOZ₂ 25-C6

Mounting height	m	2.8 - 8.5				
Influence area	m ²	100 - 400				
Electrical supply	V/ph/Hz	230/1+N/50				
Max. input current	A	1.3				
Max. input power	kW	0.29				
Max. specific fan power	W/l/s	0.32				
Weight	kg	83				
Water range	°C	6/12				
Speed		2V	4V	6V	8V	10V
Air volume	m ³ /h	443.0	1088.0	1785.0	2494.0	3215.0
Power consumption	kW	0.100	0.100	0.100	0.200	0.300
Sound pressure level at 5m	dB(A)	16.0	31.0	43.0	52.0	59.0
Air inlet temperature	°C	27				
Cooling capacity	kW	3.9	8.1	11.4	14.2	16.5
Discharge air temperature	°C	8.9	11.2	12.8	14	14.9
Water flow rate	l/h	562.0	1154.0	1637.0	2028.0	2360.0
Water pressure drop	kPa	1.4	5.2	9.9	14.7	19.3
Condensate water	l/h	1.9	3.5	4.5	5.1	5.3

NOZ₂ 50-C6

Mounting height	m	3.5 - 14.0				
Influence area	m ²	200 - 800				
Electrical supply	V/ph/Hz	400/3+N/50				
Max. input current	A	2.2				
Max. input power	kW	1.34				
Max. specific fan power	W/l/s	0.6				
Weight	kg	134				
Water range	°C	6/12				
Speed		2V	4V	6V	8V	10V
Air volume	m ³ /h	1157.0	3039.0	4908.0	6454.0	8023.0
Power consumption	kW	0.100	0.200	0.300	0.700	1.400
Sound pressure level at 5m	dB(A)	27.0	42.0	53.0	62.0	68.0
Air inlet temperature	°C	27				
Cooling capacity	kW	9.4	19.3	26.4	31.4	35.5
Discharge air temperature	°C	10.1	12.8	14.3	15.2	16.0
Water flow rate	l/h	1342.0	2771.0	3783.0	4493.0	5092.0
Water pressure drop	kPa	1.7	6.3	11.1	15.2	19.2
Condensate water	l/h	4.2	7.4	8.7	9.4	9.5

NOZ₂ 25-H(C)6 / NOZ₂ 25-(H)C6

Mounting height	m	2.8 - 8.5				
Influence area	m ²	100 - 400				
Electrical supply	V/ph/Hz	230/1+N/50				
Max. input current	A	1.3				
Max. input power	kW	0.290				
Max. specific fan power	W/l/s	0.32				
Weight	kg	83				
Water range (heating)	°C	50/30				
Inlet air relative humidity	%	50				
Speed		2V	4V	6V	8V	10V
Air volume	m ³ /h	443.0	1088.0	1785.0	2494.0	3215.0
Power consumption	kW	0.100	0.100	0.100	0.200	0.300
Sound pressure level at 5m	dB(A)	16.0	31.0	43.0	52.0	59.0
Air inlet temperature	°C	-10				
Heating capacity	kW	8.8	18.9	27.7	35.4	42.2
Discharge air temperature	°C	43.3	36.3	31.5	27.9	25.0
Water flow rate	l/h	382.0	816.0	1199.0	1529.0	1822.0
Water pressure drop	kPa	0.6	2.4	4.9	7.7	10.6
Air inlet temperature	°C	0				
Heating capacity	kW	6.9	14.7	21.5	27.4	32.6
Discharge air temperature	°C	43.5	37.5	33.4	30.4	28.1
Water flow rate	l/h	300.0	636.0	931.0	1185.0	1411.0
Water pressure drop	kPa	0.4	1.5	3.1	4.8	6.6
Air inlet temperature	°C	10				
Heating capacity	kW	5.1	10.7	15.5	19.7	23.4
Discharge air temperature	°C	43.3	38.2	35	32.7	30.9
Water flow rate	l/h	222.0	463.0	672.0	852.0	1011.0
Water pressure drop	kPa	0.2	0.9	1.7	2.6	3.6
Air inlet temperature	°C	15				
Heating capacity	kW	4.2	8.7	12.6	15.9	18.8
Discharge air temperature	°C	43	38.4	35.6	33.6	29.7
Water flow rate	l/h	183.0	377.0	544.0	687.0	813.0
Water pressure drop	kPa	0.2	0.6	1.2	1.8	2.4
Air inlet temperature	°C	18				
Heating capacity	kW	3.7	7.5	10.8	15.9	16.0
Discharge air temperature	°C	42.6	38.4	35.8	34.1	32.7
Water flow rate	l/h	160.0	325.0	466.0	587.0	693.0
Water pressure drop	kPa	0.1	0.5	0.9	1.3	1.8
Air inlet temperature	°C	20				
Heating capacity	kW	3.3	6.7	9.6	12	14.2
Discharge air temperature	°C	42.3	38.3	35.9	34.3	33.1
Water flow rate	l/h	144.0	290.0	414.0	519.0	611.0
Water pressure drop	kPa	0.1	0.4	0.7	1.1	1.4
Water range (cooling)	°C	6/12				
Inlet air relative humidity	%	48				
Air inlet temperature	°C	27				
Cooling capacity	kW	3.9	8.1	11.4	14.2	16.5
Discharge air temperature	°C	8.9	11.2	12.8	14.0	14.9
Water flow rate	l/h	562.0	1154.0	1637.0	2028.0	2360.0
Water pressure drop	kPa	1.4	5.2	9.9	14.7	19.3
Condensate water	l/h	1.9	3.5	4.5	5.1	5.3

NOZ₂ 50-H(C)6 / NOZ₂ 50-(H)C6

Mounting height	m	3.5 - 14.0				
Influence area	m ²	200 - 800				
Electrical supply	V/ph/Hz	400/1+N/50				
Max. input current	A	2.2				
Max. input power	kW	1.340				
Max. specific fan power	W/l/s	0.60				
Weight	kg	134				
Water range (heating)	°C	50/30				
Inlet air relative humidity	%	50				
Speed		2V	4V	6V	8V	10V
Air volume	m ³ /h	1157.0	3039.0	4908.0	6454.0	8023.0
Power consumption	kW	0.100	0.200	0.300	0.700	1.400
Sound pressure level at 5m	dB(A)	27.0	42.0	53.0	62.0	68.0
Air inlet temperature	°C	-10				
Heating capacity	kW	21.8	47.8	67.8	81.7	94.2
Discharge air temperature	°C	40.4	31.9	26.8	23.8	21.3
Water flow rate	l/h	944.0	2064.0	2928.0	3532.0	4070.0
Water pressure drop	kPa	0.8	3.2	6.1	8.7	11.2
Air inlet temperature	°C	0				
Heating capacity	kW	17.0	36.9	52.2	62.8	72.3
Discharge air temperature	°C	40.7	33.6	29.4	26.9	24.9
Water flow rate	l/h	736.0	1595.0	2254.0	2714.0	3124.0
Water pressure drop	kPa	0.5	2.0	3.8	5.3	6.9
Air inlet temperature	°C	10				
Heating capacity	kW	12.4	26.4	37.1	44.5	51.0
Discharge air temperature	°C	40.8	34.9	31.7	29.8	28.2
Water flow rate	l/h	536.0	1142.0	1602.0	1921.0	2205.0
Water pressure drop	kPa	0.3	1.1	2.0	2.8	3.6
Air inlet temperature	°C	15				
Heating capacity	kW	10.1	21.2	29.6	35.4	40.5
Discharge air temperature	°C	40.5	35.4	32.6	31.0	29.7
Water flow rate	l/h	437.0	918.0	1278.0	1528.0	1749.0
Water pressure drop	kPa	0.2	0.7	1.3	1.9	2.4
Air inlet temperature	°C	18				
Heating capacity	kW	8.7	18.1	25.1	35.4	34.1
Discharge air temperature	°C	40.2	35.5	33.0	31.6	30.5
Water flow rate	l/h	377.0	782.0	1083.0	1290.0	1473.0
Water pressure drop	kPa	0.1	0.5	1.0	1.4	1.7
Air inlet temperature	°C	20				
Heating capacity	kW	7.8	16.0	22.0	26.1	29.8
Discharge air temperature	°C	40.0	35.6	33.3	32.0	31.0
Water flow rate	l/h	336.0	689.0	950.0	1129.0	1287.0
Water pressure drop	kPa	0.1	0.4	0.8	1.1	1.4
Water range (cooling)	°C	6/12				
Inlet air relative humidity	%	48				
Air inlet temperature	°C	27				
Cooling capacity	kW	9.4	19.3	26.4	31.4	35.5
Discharge air temperature	°C	10.1	12.8	14.3	15.2	16.0
Water flow rate	l/h	1342.0	2771.0	3783.0	4493.0	5092.0
Water pressure drop	kPa	1.7	6.3	11.1	15.2	19.2
Condensate water	l/h	4.2	7.4	8.7	9.4	9.5

NOZ₂ COOLING

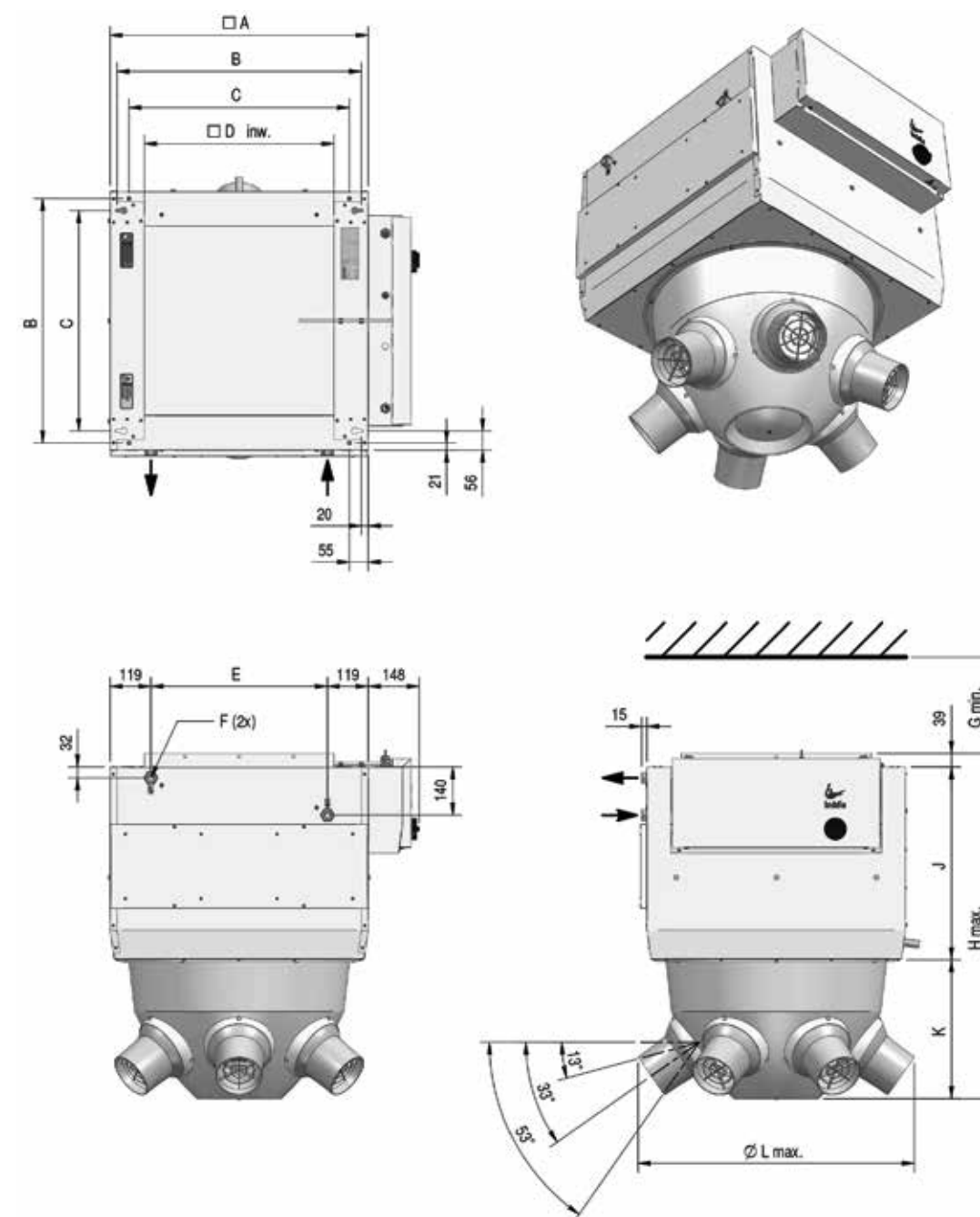

All measurements are in mm

	A	B	C	D	E	F	G	H	J	K	L
NOZ ₂ 25-C6/HC6	750.0	710.0	640.0	550.0	512.0	G3/4"	200.0	1003.0	560.0	404.0	803.0
NOZ ₂ 50-C6/HC6	975.0	935.0	865.0	775.0	737.0	G1"	300.0	1129.0	585.0	505.0	1016.0

GYUR'MA Kft
2045 Törökbálint
TT Ipartelep

T +36 1 371 3000
posta@gyurma.hu
www.gyurma.hu



Biddle